

## Globe Valve Class 300

**Standards:**

Face to Face Dimensions: ANSI B16.10  
 End Flange Dimensions: ANSI B16.5  
 26" ≥ MSS SP-44  
 Or API 605  
 Basic Design: B16.34 & BS1873  
 Test Standard: API 598

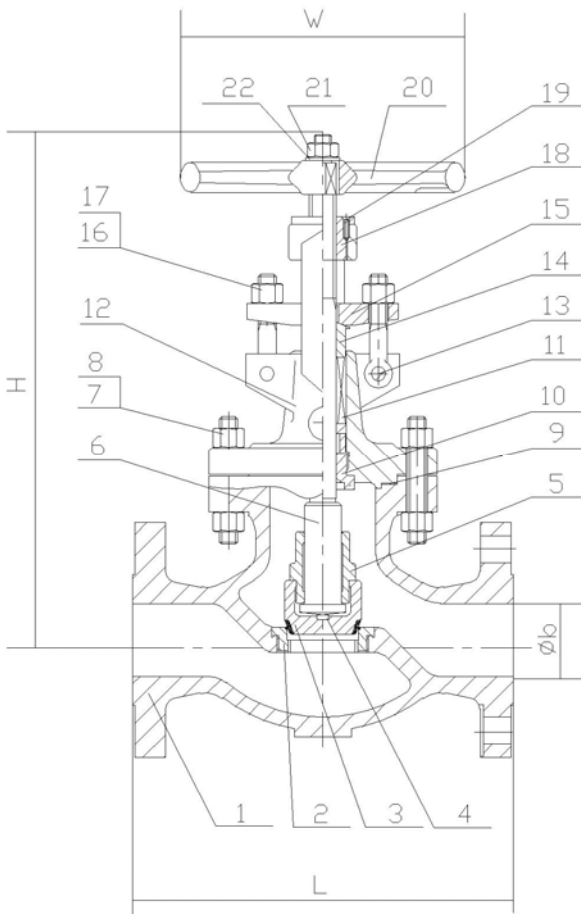

MATERIAL LIST						
NO.	Part Name	ASTM Specification (Specs – Grades/Types)				
		A 216	A 352	A 217		A 351
		WCB	LCC	WC6	C5	CF8M
1	Body	A 216-WCB	A 352-LCC	A217-WC6	A 217-C5	A 351-CF8M
2	Seat Ring	A 105, LF2, 316, or 304				
	Seat Ring Surface	13CR, HF (CoCr-A), 316, 304, or Monel				
3	Disc	A 216 – WCB	A 352-LCC	A217-WC6	A 217-C5	A 351-CF8M
	Disc Seating Surface	13CR, HF (CoCr-A), 316, 304, or Monel				
4	Disc Thrust Plate	13CR, 316, OR 304				
5	Disc Nut	13CR, 316, OR 304				
6	Stem	13CR, 316, 304, 17-4PH, or Monel				
7	Bonnet Bolt Nut	A 194-2H	A 194-4	A 194-2H	A 194-4	A 194-8
8	Bonnet Bolt	A 193-B7	A 320-L7	A 193-B7	A 193-B16	A 193-B8
9	Gasket	Spiral Wound 316/Graphite				
10	Bonnet Bushing	13CR, 316, OR 304				
11	Gland Packing	Braided Graphite & Die Formed Graphite Ring				
12	Bonnet	A 216-WCB	A 352-LCC	A217-WC6	A 217-C5	A 351-CF8M
13	Eye Bolt Pins	13CR, 316, or 304				
14	Gland	13CR, 316, or 304				
15	Gland Flange	A 216-WCB	A 352-LCC	A217-WC6	A 217-C5	A 351-CF8M
16	Gland Eye Bolts	A 193-B7	A 320-L7	A 193-B7	A 193-B16	A 193-B8
17	Eye Bolt Nuts	A 194-2H	A 194-4	A 194-2H	A 194-4	A 194-8
18	Yoke Sleeve	ASTM A 439 Gr. D2C				
19	Screw	Carbon Steel				A 276-316
20	Handwheel	Malleable Iron				
21	Handwheel Nut	Carbon Steel				A 276-316
22	Backing Ring	Carbon Steel				

DIMENSIONS AND WEIGHTS												
Size	NPS	2	2-1/2	3	4	5	6	8	10	12	14	16
L (RF)	In	10.50	11.50	12.50	14.00	15.75	17.50	22.00	24.50	28.00	33.00	34.00
	Mm	267	292	318	356	400	444	559	622	711	838	864
L (RTJ)	In	11.13	12.13	13.13	14.63	16.38	18.13	22.63	25.13	28.63	33.62	34.61
	Mm	283	308	333	371	416	460	575	638	727	854	879
L (BW)	In	10.50	11.50	12.50	14.00	15.75	17.50	22.00	24.50	28.00	33.00	34.00
	Mm	267	292	318	356	400	444	559	622	711	838	864
Øb	In	2.00	2.50	3.00	4.00	5.00	6.00	8.00	10.00	12.00	11.37	15.25
	Mm	51	64	76	102	127	152	203	254	305	337	387
H	In	16.56	17.13	17.68	20.50	24.38	25.56	31.50	41.00	44.88	50.59	56.30
	Mm	420	435	450	520	620	650	800	1040	1140	1285	1430
W	In	10	10	11.75	15.75	15.75	19.69	23.62	23.62	28.50	28.50	33.50
	Mm	250	250	300	400	400	500	600	600	720	720	850
WT	KG	31.00	40.00	58.00	86.00	130.00	150.00	397.00	527.00	608.00	630.00	880.00
	LB	68	88	128	190	287	331	875	1162	1340	1389	1940