

Check Valve Class 1500

Standards:

Face to Face Dimensions: ANSI B16.10
 End Flange Dimensions: ANSI B16.5
 Basic Design: API 594
 ANSI B16.34
 * Conforms to the applicable requirements
 of API 600
 Test Standard: API 598

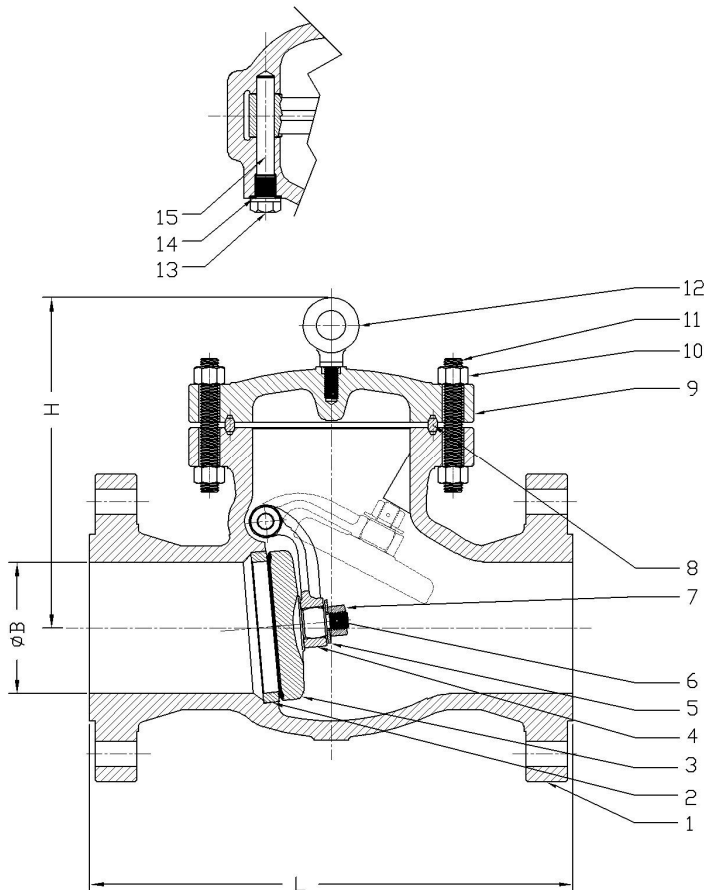

MATERIAL LIST						
NO.	Part Name	ASTM Specification (Specs - Grades/Types)				
		A 216	A 352	A 217		A 351
		WC6	LCC	WC6	WC5	CF8M
1	Body	A216-WCB	A352-LCC	A217-WC6	A217-C5	A351-CF8M
2	Seat Ring	A105	A350-LF2	A182-F11	A182-F11	
	Seat Ring Surface	13CR, HF (CoCr-A), 316, 304, or Monel				
3	Disc	A105	A350-LF2	A182-F11	A182-F11	A182-316
	Disc Seating Surface	13CR, HF (CoCr-A), 316, 304, or Monel				
4	Swing Arm	A 216-WCB	A 352-LCC	A 217-WC6	A 217-WC5	A 351-CF8M
5	Washer	ASTM A276 Gr. 316				
6	Pin	ASTM A276 Gr. 316				
7	Disc Nut	A194 Gr. 8				
8	Gasket	F5				
9	Bonnet	A216-WCB	A352-LCC	A217-WC6	A217-C5	A351-CF8M
10	Body Nut	A 193-B7	A 320-L7	A 193-B7	A 193-B16	A 193-B8
11	Body Stud	A 193-B7	A 320-L7	A 193-B7	A 193-B16	A 193-B8
12	Eyebolt	A181				
13	Hinge Pin Bolt	A 193-B7	A 320-L7	A 193-B7	A 193-B16	A 193-B8
14	Gasket	08F				
15	Hinge Pin	A276-410	A276-410	A276-410	A276-410	A276-316

DIMENSIONS AND WEIGHTS											
Size	NPS	2	2-1/2	3	4	6	8	10	12	14	16
L (RF)	In	14.50	16.50	18.50	21.50	27.75	32.75	39.00	44.50	49.50	54.50
	Mm	368	419	470	546	705	832	991	1130	1257	1384
L (RTJ)	In	14.63	16.63	18.63	21.63	28.00	33.13	39.38	45.13	50.25	55.38
	Mm	371	422	473	549	711	841	1000	1146	1276	1407
L (BW)	In	14.50	16.50	18.50	21.50	27.75	32.75	39.00	44.50	49.50	54.50
	Mm	368	419	470	546	705	832	991	1130	1257	1384
ØB	In	1.85	2.50	2.75	3.62	5.35	7.50	9.50	11.50	13.25	15.25
	Mm	47	64	70	92	136	190	241	292	336	388
H	In	12.25	12.25	13.00	14.00	15.75	20.88	22.06	25.63	30.90	36.61
	Mm	310	310	330	355	400	530	560	650	785	930
WT	KG	69	93	140	232	490	990	1490	1970	2450	3205
	LB	152.12	205.03	308.64	511.47	1080.25	2182.55	3284.85	4343.06	5401.27	7065.74