

Extended Body Gate Valve Forged Steel

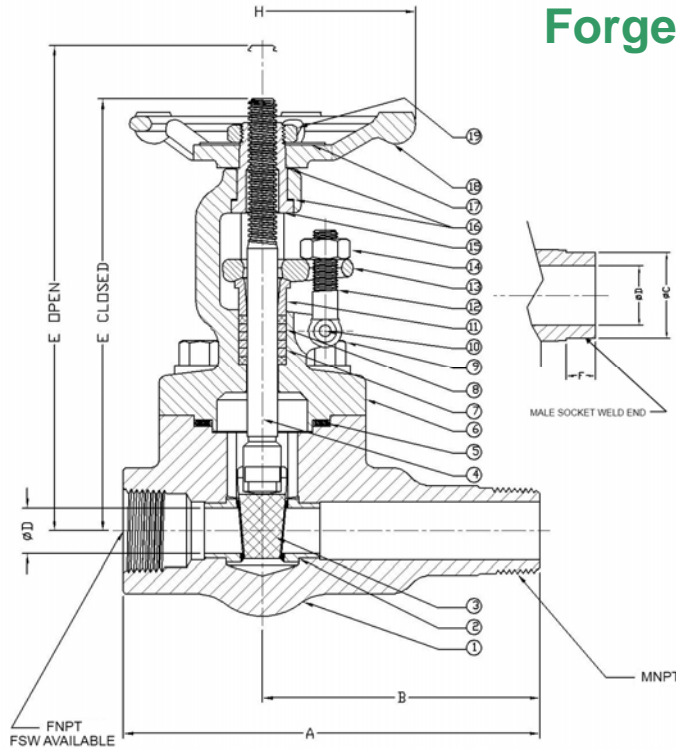

STANDARDS

DESIGN:

API 602
ASME B16.34

TESTING:

API 598

PRESSURE CLASS:

NPT, SW & BW – 800

CONNECTIONS:

NPT – ASME B1.20.1
SW - ASME B16.11
Butt Weld – ASME B16.25

MATERIAL LIST								
NO.	Part Name	A105	LF2	F5	F9	F11	F22	F316/F316L
1	Body	A105N	A350-LF2	A182-F5	A182-F9	A182-F11	A182-F22	A182-F316/F316L
2	Seat Ring	A276-410/CoCr-A						A276-316/CoCr-A
3	Gate	A276-410						A276-316
4	Stem	A276-410						A276-316
5	Gasket	Spiral Wound 304/Graphite						316/Graphite
6	Bonnet	A105N	A350-LF2	A182-F5	A182-F9	A182-F11	A182-F22	A182-F316/F316L
7	Wiper Ring	Braided Graphite						
8	Packing	Die Formed Graphite						
9	Body Bolt	A193-B7	A193-B8M	A193-B16				A193-B8M
10	Eyebolt Pin	A276-410						A276-316
11	Gland	A276-410						A276-316
12	Eyebolt	A193-B7	A193-B8M	A193-B16				A193-B8M
13	Gland Plate	A105						A182-F316
14	Gland Nut	A194-2H	A194-8M					
15	Op Nut	A276-410						A276-316
16	Washer	A276-410						
17	Nameplate	Aluminum						
18	Handwheel	KTH330-08						
19	Handwheel Nut	LY12 Steel						

DIMENSIONS AND WEIGHTS										
SIZE		A	B	C	D (Min)	EO	EC	F	H	WEIGHT
1/2"	Inch	5.89	4.33	0.84	0.37	6.30	5.83	.31	3.94	5.49
	mm	149.5	110.0	21.3	9.5	160.0	148.0	7.9	100.00	2.49
3/4"	Inch	5.77	4.33	1.05	0.51	6.65	6.02	.44	3.94	5.62
	mm	146.5	110.0	26.7	13.0	169.0	153.0	11.2	100.00	2.55
1"	Inch	6.90	4.72	1.31	0.71	7.60	6.73	.44	4.92	10.02
	mm	175.5	120.0	33.3	18.0	193.0	171.0	11.2	125.00	4.55
1-1/2"	Inch	7.87	5.51	1.90	1.14	9.69	8.31	.44	6.30	16.8
	mm	200.0	140.0	48.3	29.0	246.0	211.0	11.2	160.00	7.62
2"	Inch	8.66	5.90	2.37	1.44	11.14	9.45	.56	7.09	26.00
	mm	220.0	150.0	60.3	36.5	283.0	240.0	14.2	180.00	11.79

*1/2" MNPT VALVES ARE NOT RECOGNIZED BY API 602

Reinforced Extended Body Gate Valve Forged Steel

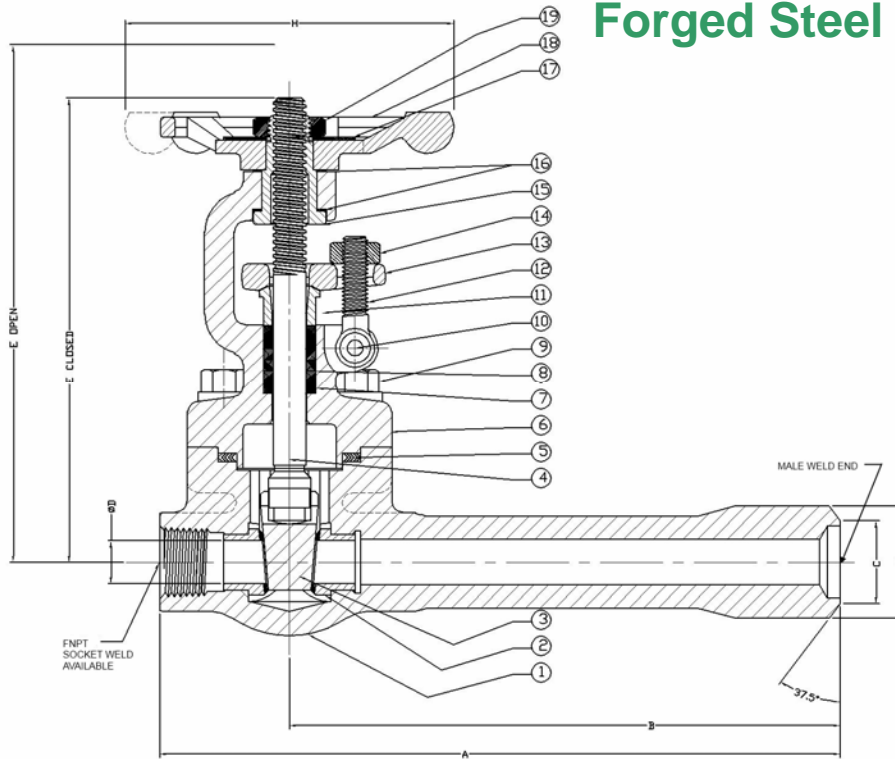

STANDARDS

DESIGN:

API 602
ASME B16.34

TESTING:

API 598

PRESSURE CLASS:

NPT, SW & BW – 800

CONNECTIONS:

NPT – ASME B1.20.1
SW - ASME B16.11
Butt Weld – ASME B16.25

MATERIAL LIST								
NO.	Part Name	A105	LF2	F5	F9	F11	F22	F316/F316L
1	Body	A105N	A350-LF2	A182-F5	A182-F9	A182-F11	A182-F22	A182-F316/F316L
2	Seat Ring	A276-410/CoCr-A						A276-316/CoCr-A
3	Gate	A276-410						A276-316
4	Stem	A276-410						A276-316
5	Gasket	Spiral Wound 304/Graphite						316/Graphite
6	Bonnet	A105N	A350-LF2	A182-F5	A182-F9	A182-F11	A182-F22	A182-F316/F316L
7	Wiper Ring	Braided Graphite						
8	Packing	Die Formed Graphite						
9	Body Bolt	A193-B7	A193-B8M	A193-B16				A193-B8M
10	Eyebolt Pin	A276-410						A276-316
11	Gland	A276-410						A276-316
12	Eyebolt	A193-B7	A193-B8M	A193-B16				A193-B8M
13	Gland Plate	A105						A182-F316
14	Gland Nut	A194-2H	A194-8M					
15	Op Nut	A276-410						A276-316
16	Washer	A276-410						
17	Nameplate	Aluminum						
18	Handwheel	KTH330-08						
19	Handwheel Nut	LY12 Steel						

DIMENSIONS AND WEIGHTS										
SIZE		A	B	C	D (Min)	EO	EC	F	H	WEIGHT
1/2"	Inch	8.15	6.59	.99	0.37	6.30	5.83	1.34	3.94	6.70
	mm	207.0	167.5	25.2	9.5	160.0	148.0	34	100.00	3.04
3/4"	Inch	8.60	6.79	1.31	0.51	6.65	6.02	1.77	3.94	7.62
	mm	218.5	172.5	33.2	13.0	169.0	153.0	45	100.00	3.46
1"	Inch	9.63	7.44	1.56	0.71	7.60	6.73	2.05	4.92	13.05
	mm	244.5	189.0	38.7	18.0	193.0	171.0	52	125.00	5.92
1-1/2"	Inch	10.37	8.01	2.11	1.14	9.69	8.31	2.75	6.30	21.93
	mm	263.5	203.5	53.7	29.0	246.0	211.0	70	160.00	9.95
2"	Inch	10.53	7.78	2.68	1.44	11.14	9.45	3.35	7.09	33.32
	mm	267.5	197.5	68.2	36.5	283.0	240.0	85	180.00	15.11