

## Cryogenic Service Gate Valve Forged Steel

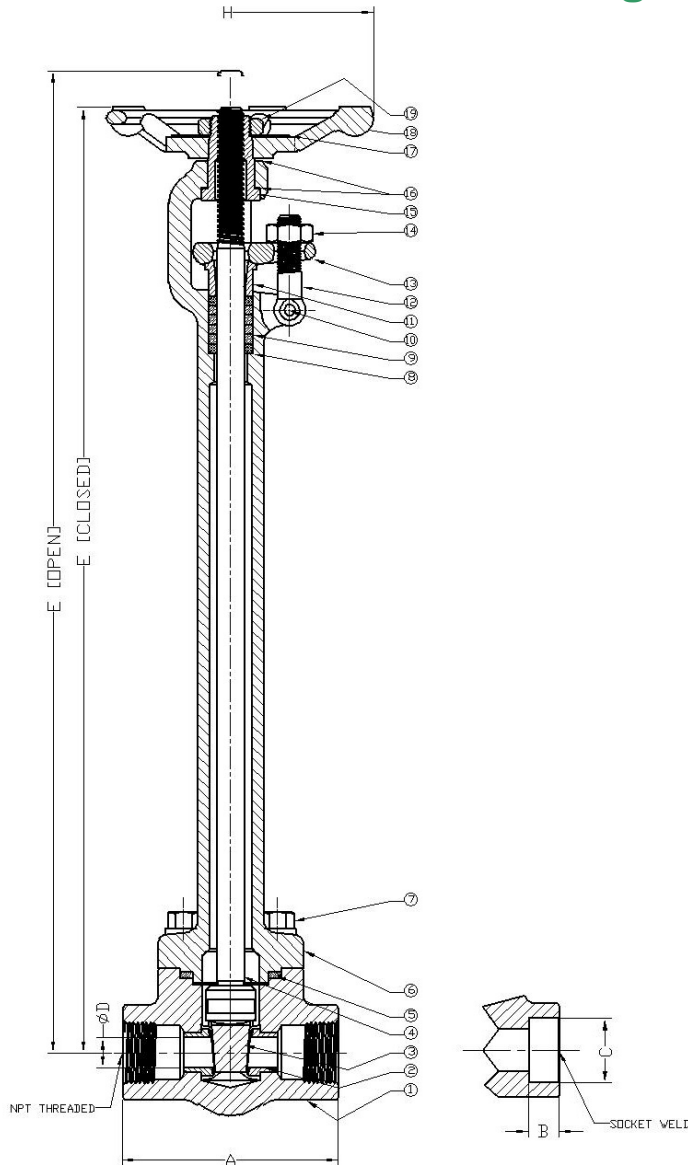

### STANDARDS

#### DESIGN:

API 602  
ASME B16.34

#### TESTING:

API 598

#### PRESSURE CLASS:

NPT & SW - 800

#### CONNECTIONS:

NPT - ASME B1.20.1  
SW - ASME B16.11

### MATERIAL LIST

NO.	Part Name	SPECIFICATION
1	Body	ASTM A182 Gr. F316/F316L
2	Seat Ring	ASTM A276 Gr. 316/CoCr-A
3	Gate	ASTM A276 Gr. 316
4	Stem	ASTM A276 Gr. 316
5	Gasket	Spiral Wound 316/Graphite
6	Bonnet	ASTM A182 Gr. F316/F316L
7	Body Bolt	ASTM A193 Gr. B8M
8	Wiper Rings	Braided Graphite
9	Packing	Die Formed Graphite
10	Eyebolt Pin	ASTM A276 Gr. 316
11	Gland	ASTM A276 Gr. 316
12	Eyebolt	ASTM A193 Gr. B8M
13	Gland Plate	ASTM A182 Gr. F316
14	Gland Nut	ASTM A194 Gr. 8M
15	Op Nut	ASTM A276 Gr. 316
16	Washer	ASTM A276 Gr. 410
17	Nameplate	Aluminum
18	Handwheel	KTH330-08
19	Handwheel Nut	LY12 Steel

		DIMENSIONS AND WEIGHTS						
SIZE		A	B	C	D (Min)	EO	EC	H
1/2	Inch	3.11	0.37	0.87	0.38	16.34	15.87	4.92
	mm	79.00	9.50	22.0	9.5	415.0	403.0	125.0
3/4	Inch	3.62	0.49	1.07	0.51	16.63	16.00	4.92
	mm	92.00	12.50	27.4	13.0	422.5	406.5	125.0
1	Inch	4.37	0.49	1.34	0.71	18.00	17.09	6.30
	mm	111.00	12.50	34.1	18.0	457.0	434.0	160.0
1-1/2	Inch	4.72	0.49	1.92	1.18	19.38	18.00	7.09
	mm	152.00	12.50	49.0	30.0	492.0	457.0	180.0
2	Inch	5.51	0.63	2.41	1.42	21.38	19.00	7.50
	mm	172.00	16.00	61.5	36.0	543.0	482.6	190.5

## Cryogenic Service Globe Valve Forged Steel

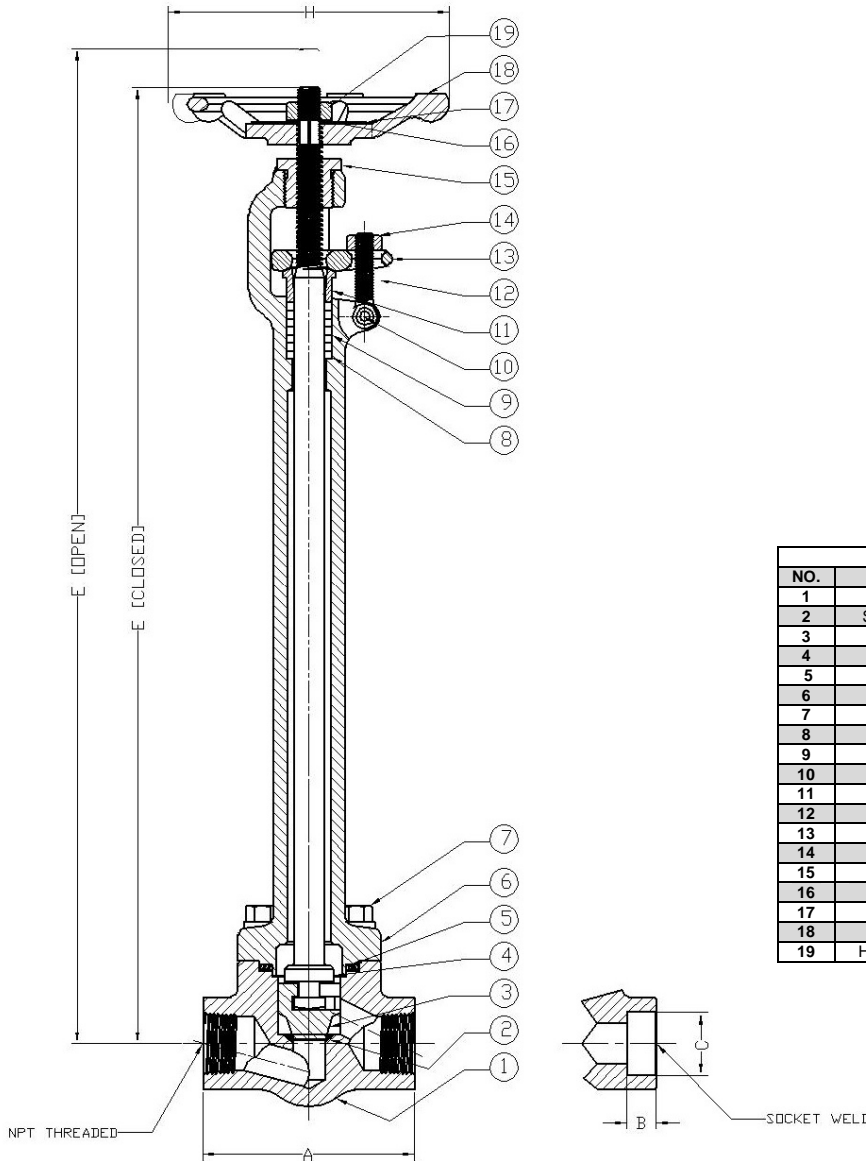

### STANDARDS

#### DESIGN:

API 602  
MSS SP-118  
ASME B16.34

#### TESTING:

API 598

#### PRESSURE CLASS:

NPT & SW - 800

#### CONNECTIONS:

NPT - ASME B1.20.1  
SW - ASME B16.11

MATERIAL LIST		
NO.	Part Name	SPECIFICATION
1	Body	ASTM A182 Gr. F316/F316L
2	Seat (Integral)	CoCr-A
3	Disc	ASTM A276 Gr. 316
4	Stem	ASTM A276 Gr. 316
5	Gasket	Spiral Wound 316/Graphite
6	Bonnet	ASTM A182 Gr. F316/F316L
7	Body Bolt	ASTM A193 Gr. B8M
8	Wiper Rings	Braided Graphite
9	Packing	Die Formed Graphite
10	Eyebolt Pin	ASTM A276 Gr. 316
11	Gland	ASTM A276 Gr. 316
12	Eyebolt	ASTM A193 Gr. B8M
13	Gland Plate	ASTM A182 Gr. F316
14	Gland Nut	ASTM A194 Gr. 8M
15	Op Nut	ASTM A276 Gr. 316
16	Washer	ASTM A276 Gr. 410
17	Nameplate	Aluminum
18	Handwheel	KTH330-08
19	Handwheel Nut	LY12 Steel

DIMENSIONS AND WEIGHTS								
SIZE		A	B	C	D (Min)	EO	EC	H
1/2	Inch	3.11	0.37	0.87	0.38	16.34	15.87	4.92
	mm	79.00	9.50	22.0	9.5	415.0	403.0	125.0
3/4	Inch	3.62	0.49	1.07	0.51	16.63	16.00	4.92
	mm	92.00	12.50	27.4	13.0	422.5	406.5	125.0
1	Inch	4.37	0.49	1.34	0.71	18.00	17.09	6.30
	mm	111.00	12.50	34.1	18.0	457.0	434.0	160.0
1-1/2	Inch	4.72	0.49	1.92	1.18	19.38	18.00	7.09
	mm	152.00	12.50	49.0	30.0	492.0	457.0	180.0
2	Inch	5.51	0.63	2.41	1.42	21.38	19.00	7.50
	mm	172.00	16.00	61.5	36.0	543.0	482.6	190.5